

Design Changed		TYPE	L - SERIES		APPROVED BY	JUNG,M,C	CHECKED BY	JUNG,M,C	 JUNGIL MACHINERY CO.
		SIMILAR DWG.			DESIGNED BY	J.H CHOI	DRAWN BY	J.H CHOI	
		REMARK			TITLE	OIL BUFFER			

NOTE

- OIL SPEC : ISO VG 32
- FIN. : PAINT E33720
- PLUNGER COVER : BLACK
- NAME PLATE : 별도도면 참조
- 오일은 년 1회이상 점검 후 오일량 부족시 보충할 것.

G NO. TABLE

G.NO	MODEL	A	B	C	D	E	STROKE	OIL[l]	WEIGHT[kg]	RATED SPEED	APPLICABLE MASS
01	L1	2687	1455	1207	1060	1582	1105	19.7	96.0	4m/s (240m/min)	1500 ~ 6000kg
02	L2	4215	2088	2102	1695	2475	1740	30.8	136.6	5m/s (300m/min)	2000 ~ 6000kg

Q'TY					P.N	DRAWING. NO	PART NAME	SIZE	MAT'L	W.T
G5	G4	G3	G2	G1		JB1118	P01	OIL BUFFER ASS'Y		
			1	1	01					
			1	1	02		P02	CYLINDER		
			1	1	03		P03	PLUNGER		
			1	1	04		P04	CAM		
			1	1	05		P05	BRACKET		
			2	2	06		P06	HEXA. BOLT, S/W	M8 X 15L	
			1	1	07		P07	COVER		
			1	1	08		P08	GAUGE		
			1	1	09		P09	CAP	PT 1/2"	
			2	2	10		P10	통근머리 BT,NT,PW,SW	M4 X 30L	
			1	1	11		P11	SWITCH		

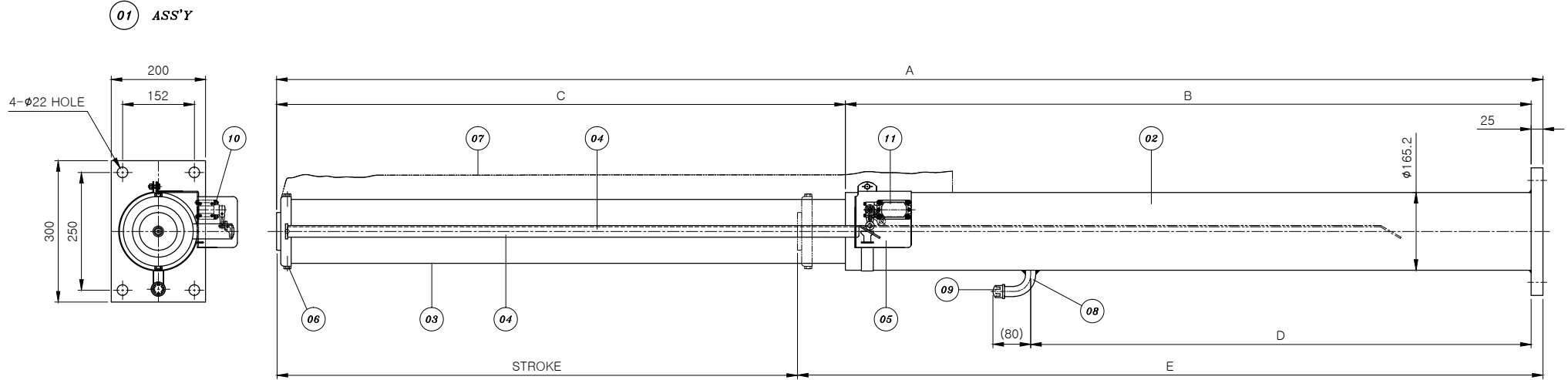

DWG.NO	JB1118	SCALE	1:8	A3
--------	--------	-------	-----	----